

A (2:1)
Antrieb

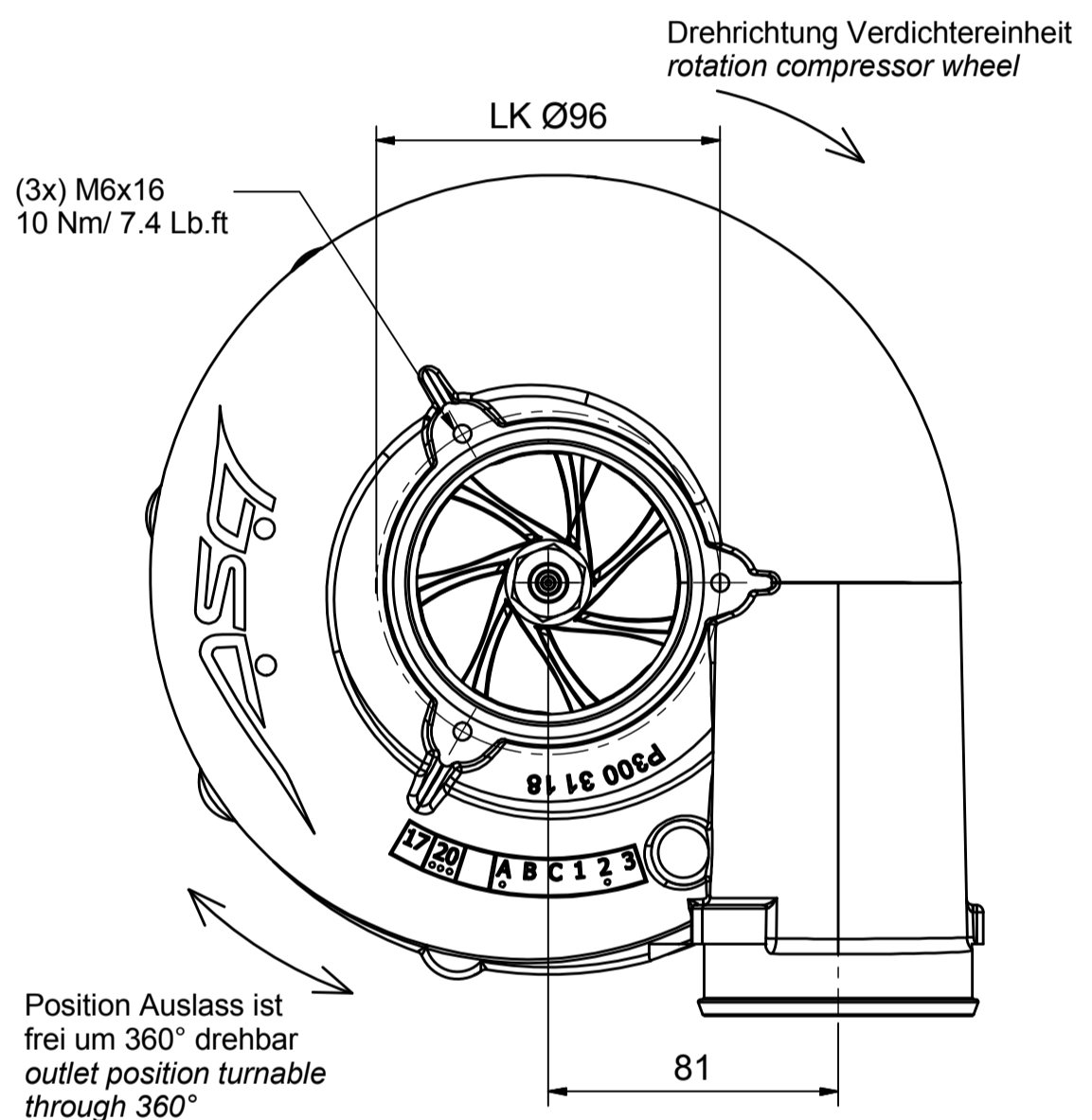

Gewicht ohne Kupplung (without pulley/without clutch)	5,9 kg
Innere Übersetzung: (inner gear ratio)	1:15
Ölvolumenstrom (übliche Motorenöle): (oil volume flow-usual engine oil)	1,2-1,6 l/min
Min. / Max. Öleintrittstemperatur (min. / max. oil inlet temperature)	-40°C/105 °C
Nenn Drehzahl (rpm level)	100.000 1/min
Luftmasse (air mass) max. T1-316	2.100 kg/h
Leistungsbereich (power range)	680 PS
Max. Druckverhältnis p2/p1 (max. pressure ratio)	2.6
Massenträgheitsmoment (mass moment of inertia)	auf Anfrage on request

Verdichterkennfeld flow chart T1-523 (9477)

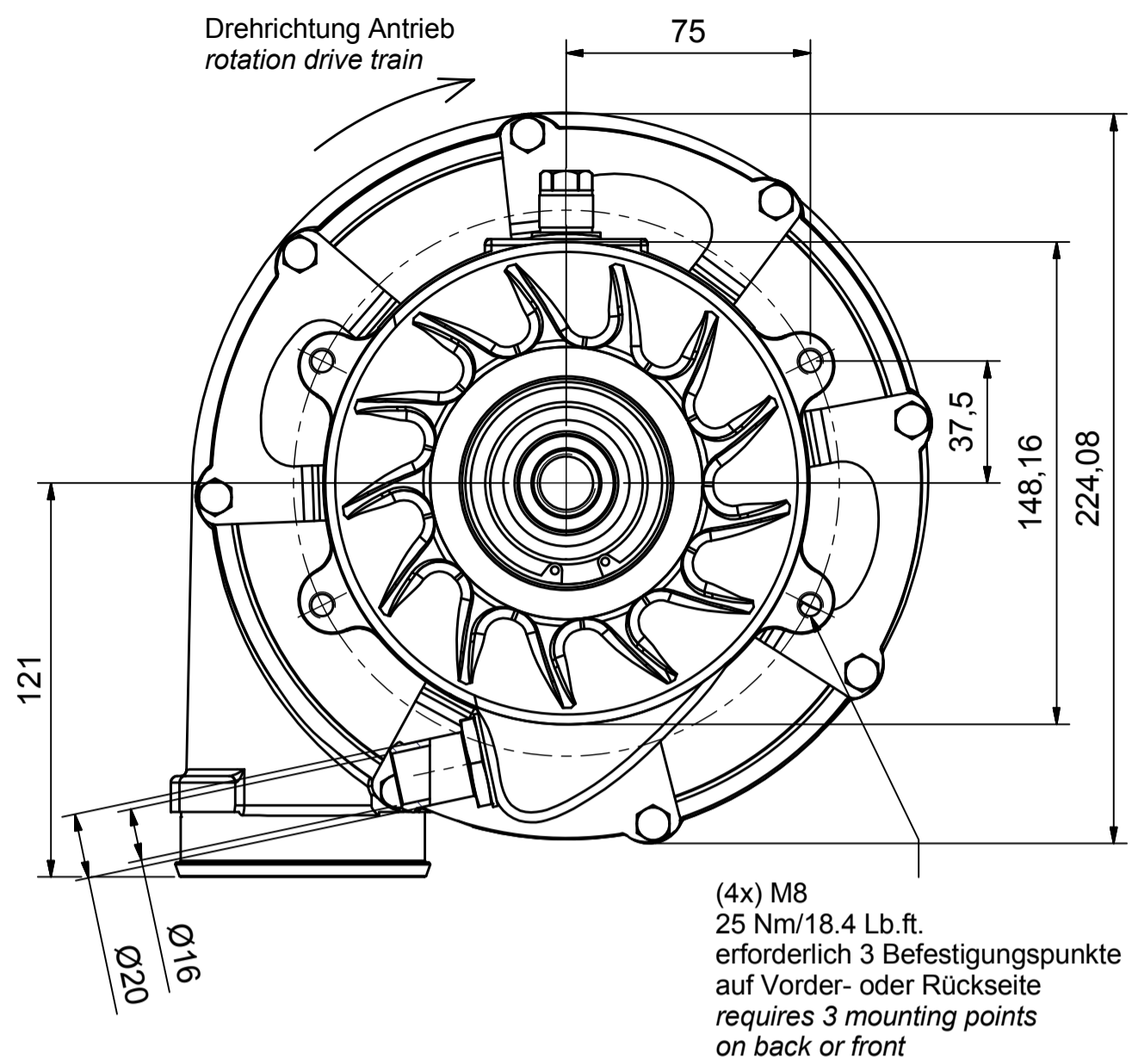
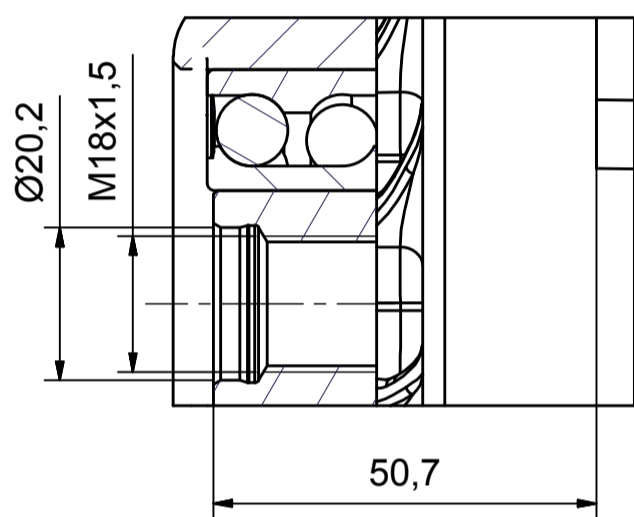