

Kompressor T1-724

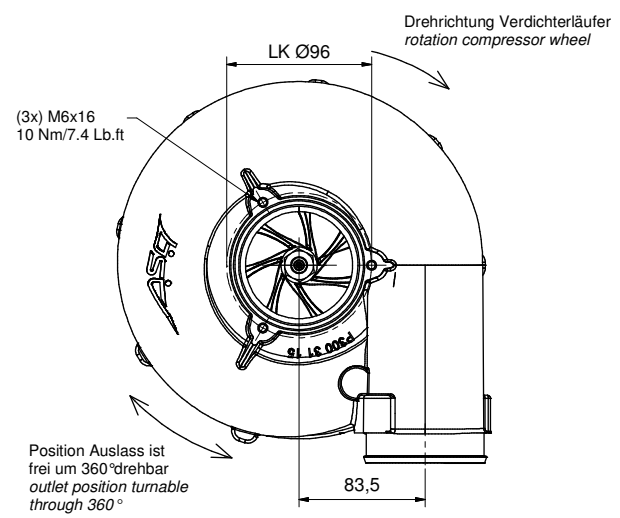

Gewicht ohne Kupplung (without pulley/without clutch)	7,5 kg
Innere Übersetzung: (inner gear ratio)	1:15
Ölvolumenstrom (übliche Motorenöle): (oil volume flow-usual engine oil)	1,2-1,6 l/min
Min./Max. Öleintrittstemperatur (min./max. oil inlet temperature)	-40 °C/105 °C
Nenn Drehzahl (rpm level)	100.000 1/min
Luftmasse (air mass) max. T1-316	2.250 kg/h
Leistungsbereich (power range)	740 PS
Max. Druckverhältnis p2/p1 (max. pressure ratio)	2.7
Massenträgheitsmoment (mass moment of inertia)	Auf Anfrage (on request)

Verdichterkennfeld flow chart T1-724

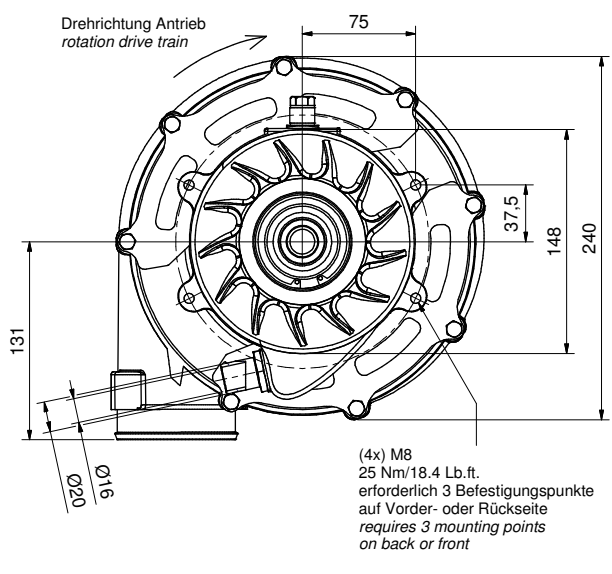
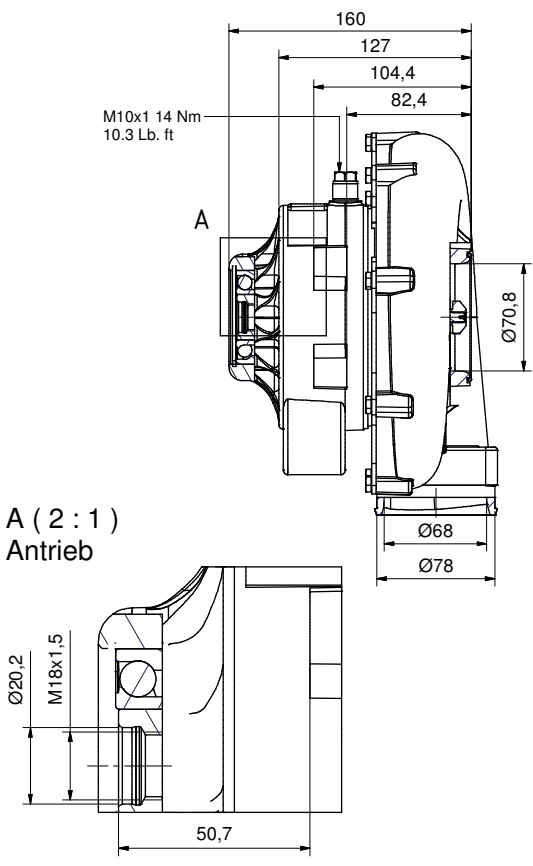
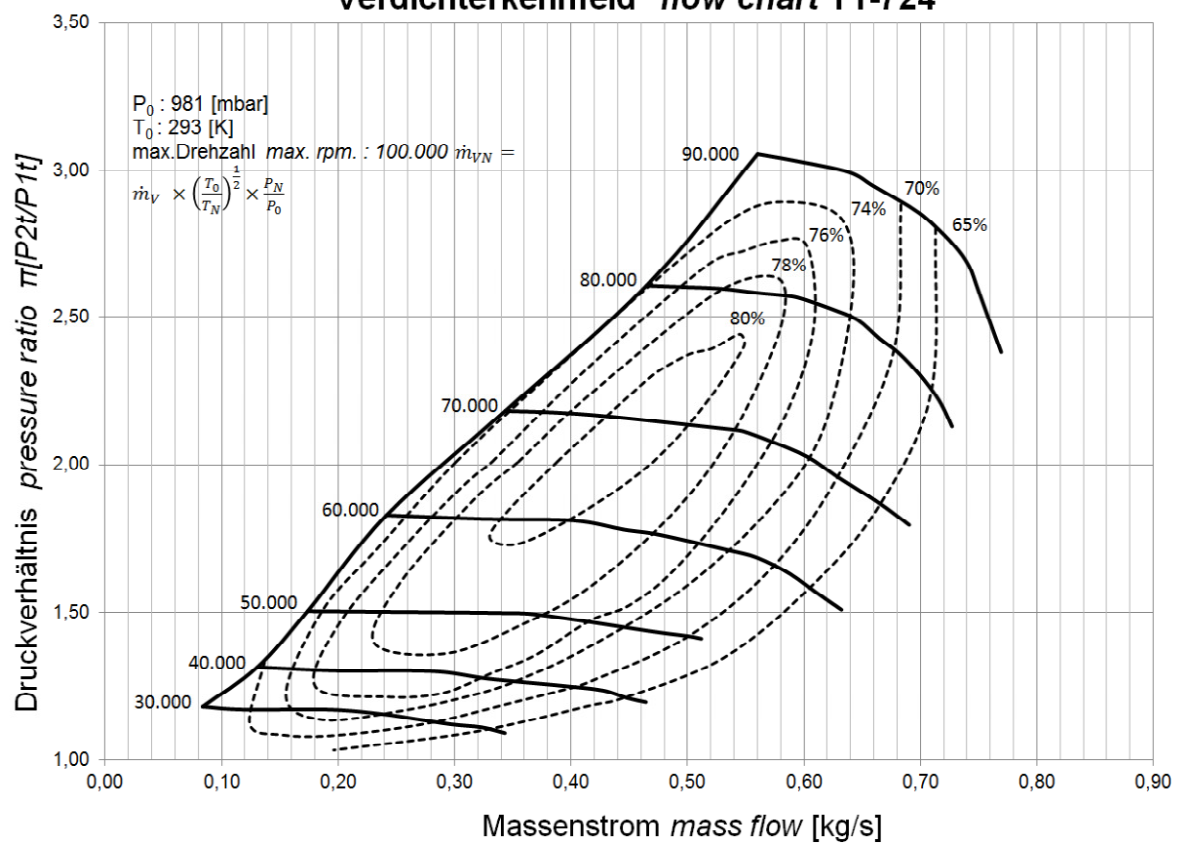

Datenblatt data sheet